

Product Data Sheet – Transport Trolley

Model No: - TW 52/800

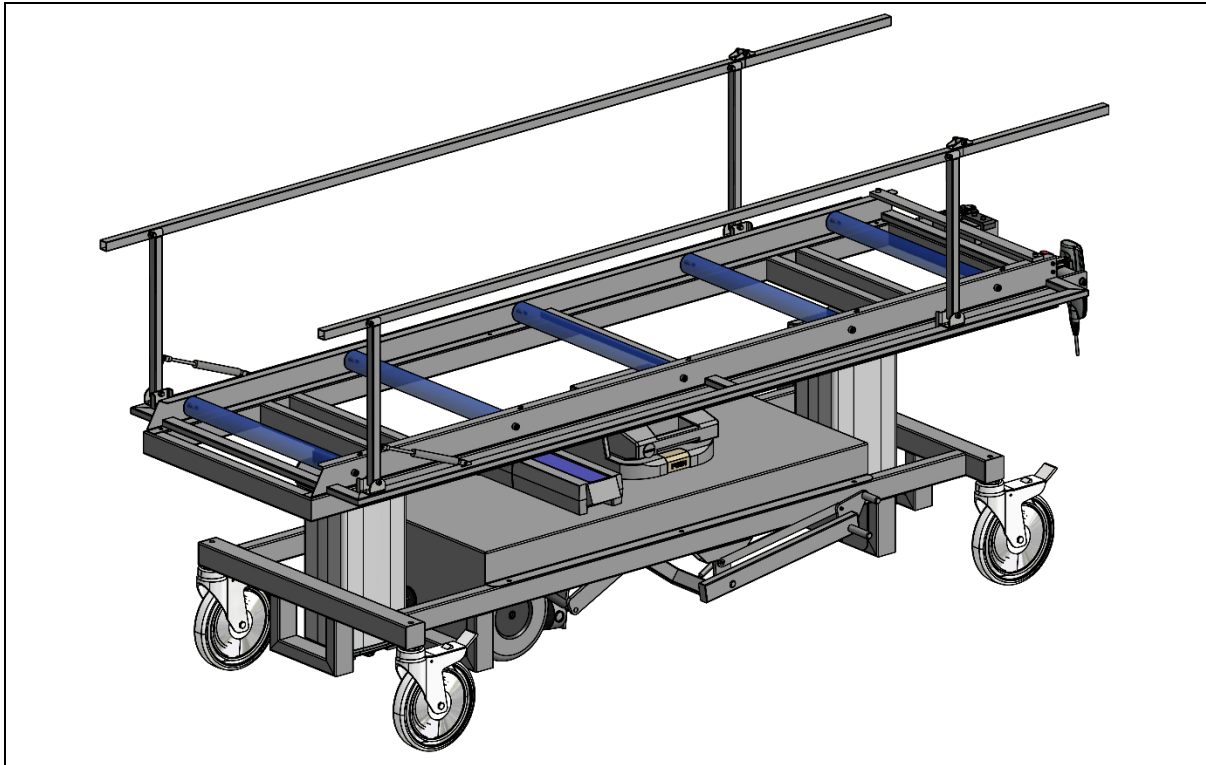

The transport trolley designed is to meet the needs of retrieving and transporting deceased between the ward and mortuary.

Designed with a rugged, torsion-resistant frame constructed from high quality powder coated steel. The trolley is fitted with 200mm diameter heavy duty caster wheels that are permanently lubricated and maintenance-free to ensure easy and silent movement. In addition the trolley can be moved with the aid of the on board 24V traction drive system that allows the trolley to be easily moved even with heavy loads. The trolley speed can be adjusted smoothly with the control panel. The battery is replaceable allowing a spare battery to be on charge at all times if required.

The top deck is height adjustable at each end independently. This allows the top deck to be matched up to the bedside for an easy transfer.

The trolley can be fitted with a variety of top decks to suit the needs of the users; these include roller systems (suitable for roll on body trays), wet top fixed trays and flat tops.

Technical Data:

Dimensions lowest Position W/D/H: 2150 x 725 x 650 mm
Dimensions highest Position W/D/H: 2150 x 725 x 1050 mm
Carrying capacity: max. 350 kg
Dead weight: approx. 130 kg
Inline: approx. 15°
Material: Powder coated steel and stainless steel
Colour: Lightgrey RAL 7035 (powder coated)
Type: TW 52/800